



OWNER'S MANUAL

INSTALLATION INSTRUCTIONS

SELF-PRIMING CENTRIFUGAL PUMPS

GENERAL DESCRIPTION

This unit consists of a self-priming single-stage centrifugal pump, close-coupled to a gasoline or diesel engine, electric motor or transmission head driver. Its self-priming action is accomplished by the automatic recirculation of water during the priming cycle. There are no valves other than the check valve at the suction inlet. This type of pump operates best on total suction lift not exceeding 15 feet, but it will pump satisfactorily from depths to 25 feet at some reduction in capacity.







INSTALLATION

Locate the pump as close to the water as possible. This will reduce the suction lift to provide maximum output. The unit should be set firmly in a level position. This is particularly important for engine-driven and transmission head units to insure the proper operation for the lubrication system. No foundation is necessary unless the installation is to be permanent.

PIPELINES AND HOSES. Keep the suction and discharge lines as large as possible. Avoid using bends, elbows and fittings whenever possible. All suction connections must be airtight. Use pipe compound on all threaded joints. Always use a suction strainer to prevent large solids and foreign matter from being drawn into the pump.

ENGINE DRIVE. Check that the engine and pump are free to rotate by turning the engine hand-crank slowly through a complete revolution.

ELECTRICAL

-  **WARNING:** Hazardous voltage, can shock, burn, or cause death.
-  **WARNING:** Ground motor before connecting to electrical power supply.
-  **WARNING:** Failure to ground motor can cause severe or fatal electrical shock.
-  **WARNING:** Do not ground to a gas supply line.
-  **WARNING:** To avoid dangerous or fatal electrical shock, turn OFF power to motor before working on electrical connections.
-  **WARNING:** Supply voltage must be within 10% of nameplate voltage, Incorrect voltage can cause fire or seriously damage motor and voids warranty. If in doubt, consult a licensed electrician.

-  **CAUTION:** Before using pump, check your motor nameplate for voltage. Your electric supply voltage and the stamped nameplate voltage **must match**. Motors stamped 200 volts only or 230 volts only **must be used with that voltage only**. Motors stamped with two voltages (for example 230/460 volts) may be used with either supply voltage. For these motors check the connections against the wiring diagram on the motor nameplate and make any changes necessary to agree with your supply voltage. If in doubt, call a licensed electrician. Incorrect voltage will cause serious damage to the motor.

Some models are equipped with three phase motors. Three phase motors require magnetic starters.

To check motors for proper rotation: Remove the motor end cover. This exposes the motor shaft. If hook-up is correct, the shaft will rotate clockwise. If rotation is not clockwise, see motor nameplate for installation information. **BE SURE** the power is off when working on electrical connections.

-  **CAUTION:** Motors can operate at high temperature and will be too hot to touch. It is protected from heat damage during operation by an automatic internal cutoff switch. Before handling pump or motor, allow it to cool for 20 minutes.

WIRING

1. Install, ground wire and maintain this pump in accordance with your local electrical code and all other codes and ordinances that apply. Consult your local building inspector for local code information.
2. Ground the pump permanently using a ground strap of size and type specified by local or National Electrical Code.

OPERATION

PRIMING. Remove the priming plug from the top of the pump case. Fill the pump case completely with water. Refit the plug. **NEVER OPERATE THE PUMP WITHOUT WATER IN THE PUMP CASE.**

STARTING. Engage the motor switch, or start the engine in accordance with the manufacturer's instructions. The pump will deliver water as soon as the self-priming action has displaced the air from the suction pipe.

CAUTION: Never run the pump dry. Running the pump without water may cause the pump to overheat, damaging the seal and possibly causing burns to person(s) handling the pump. Fill the pump with water before starting.

WARNING: Never run the pump against a closed discharge. Doing so can boil water inside pump, causing hazardous pressure in unit, risk explosion, and possibly scald person(s) handling pump.

MAINTENANCE

CLEANING THE PUMP. Run clear water through the pump if possible after pumping dirty water. Do this for two or three minutes before stopping the engine or motor.

LUBRICATION

SEAL: The purpose of the mechanical seal is to prevent air from entering the pump around the shaft while priming or pumping and to prevent water from leaking out around the shaft while pumping. The seal must be kept lubricated by the liquid being pumped and should NEVER BE ALLOWED TO RUN DRY.

DISMANTLING AND REASSEMBLING OF PUMP

WARNING: Hazardous Voltage

Be sure unit is grounded and power disconnected before attempting any work on the pump or motor.

Remove capscrews which fasten pump case to bracket. Separate case and bracket gradually and carefully so as not to damage them or the assembly gasket. If the gasket tears, it must be replaced with a new one. If the old gasket is to be used again, place it in water to keep it soft and pliable.

- a. To remove impeller, hold the pump shaft from turning with an open-end wrench, and spin off the impeller in counter-clockwise direction. With engine-driven models, prevent shaft from turning by inserting Allen wrench in the setscrew or other suitable method.
- b. Remove and replace seal, if necessary, as described below.

REPLACING THE SHAFT SEAL: Handle the shaft seal with great care. Do not drop the carbon sealing washer or the ceramic-floating seat.

After removing the impeller, slide the rotating portion of the old seal assembly (consisting of sealing washer, bellows, metal parts and spring) off the pump shaft. Press the old seat and ring out of the bracket. Lubricate the outside diameter of

the new rubber seat with light oil; press the new seat and ring assembly into the bracket cavity, making certain that it is seated firmly and squarely. If the seat and ring cannot be pressed into place with the fingers, cover the lapped seat face with the cardboard ring (packed with each new seal assembly), and tap seat and ring into place by placing a small wood block squarely against the seat and tapping lightly with a light wooden mallet.

Be sure the pump shaft and sleeve is clean and smooth, or replace shaft sleeve if pump is equipped with separate sleeve. Ensure that the lapped surfaces of the seal components are kept absolutely clean during installation. Use a thin coat of light oil on the seal, and shaft when sliding the rotating portion of the seal onto the shaft. Ensure the carbon washer is facing the floating seat in the bracket. Push only against the rubber face of the seal assembly when sliding it onto the shaft.

- c. If pump shaft needs to be removed, the pump bracket must be separated from the motor and the shaft set screws loosened with a hex key (for units with a stub shaft only).
- d. Re-assemble the pump by following above described steps in reverse order. Make sure that the pump shaft is positioned on motor shaft so that impeller will rotate freely inside the pump case. Setscrews must seat properly in the motor shaft keyway and be tightened securely.

REPAIR PARTS

Clean and inspect all parts for wear or damage. Worn or deteriorated parts should be replaced with new parts from the factory. Order parts from the Repair Parts List and state the complete pump nameplate information when ordering (not motor nameplate data).

Motor service and parts can best be obtained from the motor manufacturer's authorized repair shop in your area. Contact the factory for further assistance.

LUBRICATION - ENGINE

Refer to the manufacturer's instruction manual.

LUBRICATION - MOTOR

Relubrication of the motor bearings is required only at infrequent intervals. Refer to manufacturer's instructions.

DRAINING

Remove the lower drain plug to drain the pump case when the unit is idle, during freezing weather, or in storage and let it drain completely.

IMPELLER CLEARANCE

The clearance between the impeller face and the face of the case (JM series) (or between impeller eye and case H series) should be between .005 and .010 inch. Re-adjust the clearance as follows: Loosen the set screws in the stub shaft coupling. Move the stub shaft along the driver shaft to obtain the required clearance. Re-tighten the setscrews.

SERVICE SUGGESTIONS. Should the pump fail to prime or stop pumping during operation, check for the following:

- a. Air leaks in the suction line and fittings.
- b. Air leaks in the shaft seal.
- c. Proper submergence of the suction strainer.
- d. Suction strainer clogged by debris.
- e. Suction strainer buried in mud.
- f. Sufficient priming water in pump case.
- g. Suction hose with collapsed lining.
- h. Priming port clogged.
- i. Impeller clogged or broken.

SEAL REPLACEMENT INSTRUCTIONS

FIGURE 5A

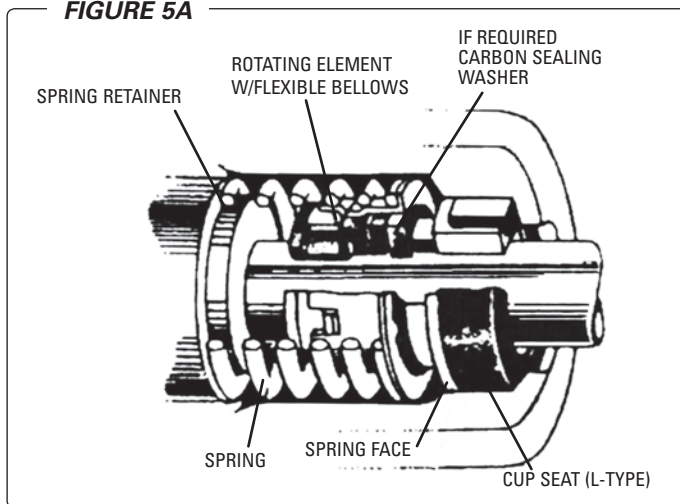

TO REPLACE SEAL



CAUTION: As sealing faces are matched parts, the shaft seal must be replaced as a complete assembly. Extreme care must be taken to keep seal faces and components perfectly clean during assembly.

1. Inspect and clean the stub shaft (or shaft sleeve) and replace on the driver shaft and key. (Shaft sleeve gasket must be installed between sleeve and shaft shoulder).
2. Install the stationary seal face and gasket.
3. Replace the bracket on the driver and tighten the assembly capscrews.
4. Apply a light coating of grease to the stub shaft or shaft sleeve and push shaft seal against the seal face already installed. Take care not to cut or invert the neoprene bellows while installing over the shaft shoulder.
5. Replace the impeller, making sure the seal spring goes over impeller hub and the impeller key is in position.
6. Replace the impeller lock capscrews and adapter (or washer) and tighten firmly.
7. Replace the pump case using a new assembly gasket.
8. Re-check impeller clearance again before operating pump. Impeller clearance should be .005 to .010 inches from the case.

TO REMOVE SEAL

1. Remove pump case from pump bracket.
2. Remove impeller lock capscrew and adapter (or washer) and pull off impeller.
3. Remove pump bracket with seal assembly from the driver.
4. Remove the stub shaft or shaft sleeve.
5. The rotating seal assembly should now be loose and easily removed.
6. Remove the stationary seal face and gasket from bracket.



22069 Van Buren Street • Grand Terrace, CA 92313-5607
Phone: (229) 226-5255 • (800) 843-9222
Fax (229) 226-5567 • (909) 422-1787
email: griswold@griswoldpump.com
website: www.griswoldpump.com



Your Distributor: